

ATTENZIONE: PER TENSIONI SPECIALI, SPECIFICARE SEMPRE IL MODELLO DI FORNO ED IL NUMERO DI MATRICOLA
ATTENTION: FOR SPECIAL VOLTAGES, PLEASE ALWAYS SPECIFY THE OVEN MODEL AND THE SERIAL NUMBER

ATTENTION: POUR TENSIONS SPÉCIALES, MERCI DE SPÉCIFIER TOUJOURS LE MODÈLE DU FOUR ET LE NUMÉRO DE SÉRIE
ACHTUNG: BEI SONDRSPANNUNGEN, BITTE IMMER OFEN-MODELL UND SERIENNUMMER GEBEN.

ed. 0713

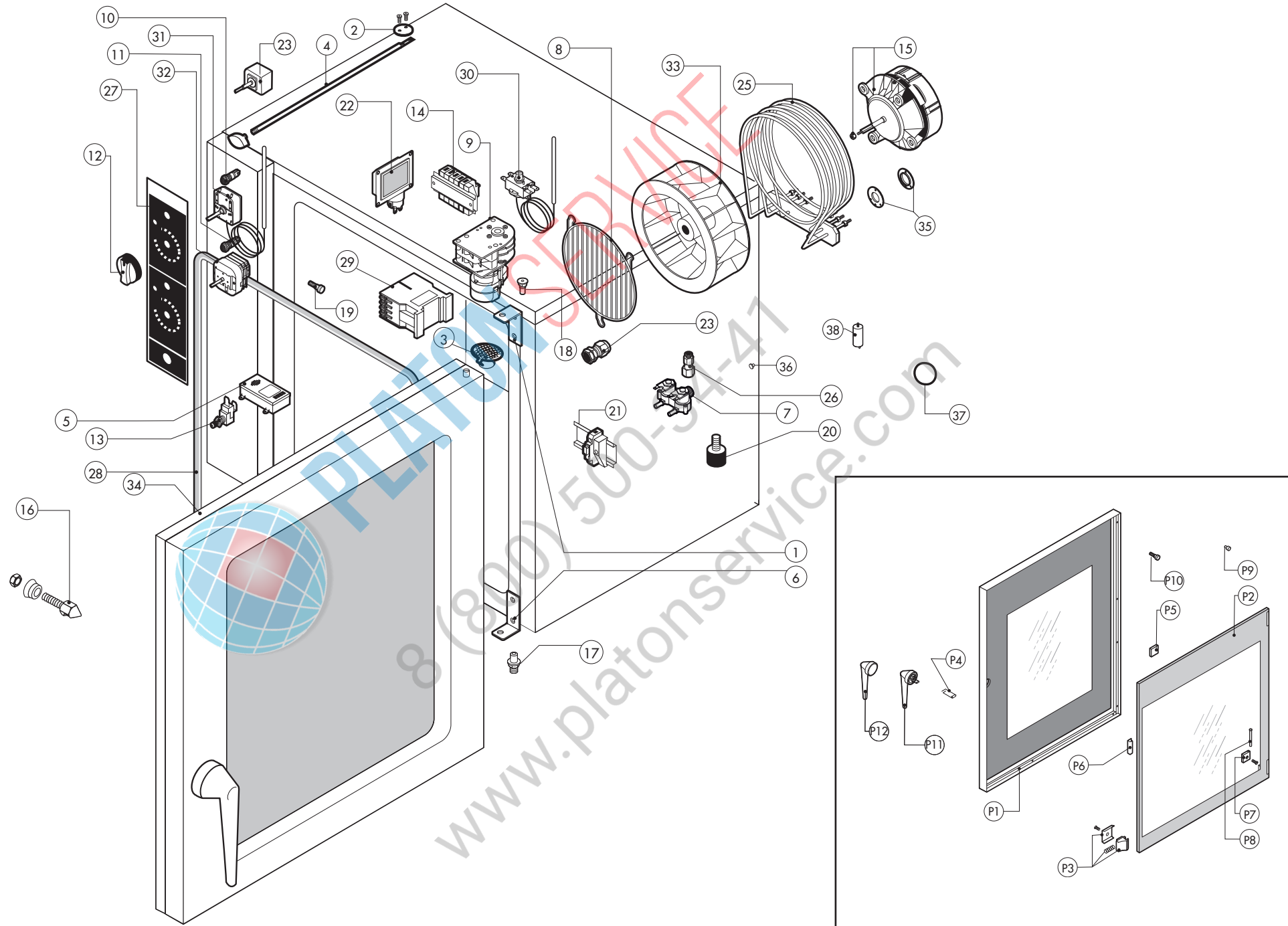

TAV. A

REP 084-104 M

POS.	COD.	Pz.	DESCRIZIONE	DESCRIPTION	DESCRIPTION	BESCHREIBUNG	DESCRIPCIÓN
1	R17201110	1	ASS.CERNIERA SUPPORTA REC-REV-REP 2011	UPPER HINGE	CHARNIERE SUPERIEUR	OBERES SCHARNIER	BISAGRA SUPERIOR
2	R18200600	1	ASS.FARFALLA M_042/051 REV M	CHAMBER VENT PLATE	ENTFEUCHUNGSSCHIEBER	DISQUE EVENT	DISCO RESPIRADERO
3	R10201700	1	ASS.FILTRO DI SCARICO D.76/44.5 M/106-11	DRAIN FILTER	FILTRE ENCEINTE	ABFLUSSFILTER	FILTRO DESAGUE
4	R58004850	1	ASTA SFIATO M6 L=640 REP M	CHAMBER VENT ROD	BARRE COMMANDE EVENT	SCHIEBERACHSE	EJE RESPIRADERO
5	R65330050	1	BUZZER TEMPOR.3" 230V C/SCAT.	BUZZER 3"	SONNERIE 3"	SUMMER MIT ZEITGLEID	ZUMBADOR TEMPORIZADO 3"
6	R17403910	1	CERNIERA INF. PORTA REGOL.REC-REV-REP	LOWER HINGE	CHARNIERE INFERIEUR	UNTERES SCHARNIER	BISAGRA INFERIOR
7	R65110210	1	E.V. 2 VIE 220V 50HZ X J.G.CON ATTACC	SOLENOID VALVE 220V 50HZ	ELECTROVANNE 220V 50HZ	MAGNETVENTIL 220V 50HZ	ELECTROVALVULA 220V 50HZ
8	R75300150	2	GRIGLIA VENTILATORE D.170	FAN GUARD GRID D.170	GRILLE VENTILATEUR D.170	VENTILATORSCHUTZGITTER D.170	REJILLA VENTILADOR D.170
9	R65090170	1	INVERSORE CICLICO 8' 3 CAMME	REVERSING SWITCH	INVERSEUR	POLWENDER	INVERSOR CICLICO
10	R65270300	2	LUCE SPIA GIALLA ALPHATECH SL 656 TZB	ORANGE INDICATING LIGHT	LAMPE TEMOIN ORANGE	ORANGENE KONTROLLAMPE	LAMPARA PILOTO NARANJA
11	R65270320	1	LUCE SPIA VERDE ALPHATECH SL 656 TZA	GREEN INDICATING LIGHT	LAMPE TEMOIN VERT	GRUENE KONTROLLAMPE	LAMPARA PILOTO VERDE
12	R69030170	3	MANOPOLA NEUTRA NERO/GRIGIA D.42	KNOB KIT	POIGNEE COMMANDE	DREHKNOPF	PULSADOR MANETA
13	R65260540	1	MICRO PORTA	DOOR SWITCH	MICRO PORTE	TUERSCHALTER	MICRO PUERTA
14	R65220091	1	MORSETTIERA LX2E (TIPO 2) NEW	TERMINAL BOARD	BORNIER	KLEMMLEISTE	REGLETERA
15	R65041040	2	MOTORE 1F.125Win-75Wout 2VEL C/COND. FIR	MOTOR	MOTEUR	MOTOR	MOTOR
16	R69010260	1	NASELLO 1 STEP 6303-020022	DOOR LATCH 1 STEP	GACHE DE PORTE POUR OUVERTURE SIMPLE	SCHLISSNASE 1 STUFE	NARIZ 1 CIERRE
17	R58002520	1	PERNO INF.CERNIERA REG. V/061-102	LOWER HINGE PIN	CHEVILLE CHARNIERE INFERIEURE	UNTERES SIE SCHARNIERSTIFT	PERNO INFERIOR BISAGRA
18	R58002150	1	PERNO SUP.CERNIERA REG. M/106-220	UPPER HINGE PIN	CHEVILLE CHARNIERE SUPERIEURE	OBERES SCHARNIERSTIFT	PERNO SUPERIOR BISAGRA
19	R58001850	16	PERNO SUPP. PARATIE M5 MIXTER	RACK HOLDER	BOLZEN AUFLAGESCHIENEN	SUPPORT GLISSIERE	PERNO SOPORTE MAMPARO
20	R69070220	4	PIEDINO INOX+NYLON D.40 H TOT.60 FIL.M10	FOOT	VERIN	ZYLINDRISCHER FUSS	PIE ACERO
21	R65210020	2	PORTAFUSIBILE BARRA DIN 5x20	FUSE CARRIER	PORTE-FUSIBLE	SICHERUNGSHALTER	PORTAFUSIBILE
22	R65270510	2	PORTALAMPADA STAGNO ALPHATECH 77.705.U10	WATERPROOF LIGHT SOCKET	DOUILLE ETANCHEE	DICHTE LAMPEHALTERUNG	PORTALAMPARA ESTANCO
23	R65240200	1	PRESSACAVO V-TEC 21 NERO	FAIRLEAD	PRESSE CABLE	ZUGENTLASTUNG	PRENSACABLES
24	R65080250	1	REGOLATORE ENERGIA 50.57021.010	ENERGY REGULATOR	REGULATEUR D'ENERGIE	ENERGIEREGLER	REGULADOR ENERGIA
25	R65011730	2	RESIST.7000W230V CAM. ALPHA INCOLOY800	HEATING ELEMENT	RESISTANCE	HEIZKOERPER	RESISTENCIA
26	R62090788	2	RIDUZIONE INTER.DRITTA ø10-ø6 PM201006E	REDUCTION	REDUCTION	VERRINGERUNG	REDUCCION
27		1	TASTIERA	PLATE	PLAQUE	BEDIENUNGSFOLIE	TARJETA
28	R70044440	1	TELAIO GUARNIZIONE PORTA REP 084/104	FRONT GASKET	JOINT FACADE	DICHTUNG DER FRONTSEITE	JUNTA FRONTAL
29	R65140400	2	TELERUTTORE 3RT1025-1AL20 SIEMENS	CONTACTOR	CONTACTEUR	SCHUETZ	CONTACTOR
30	R65070460	1	TERMOST.SICUR.BIP.360°C NEGAT.	THERMOSTAT	THERMOSTAT	THERMOSTAT	TERMOSTATO
31	R65070400	1	TERMOSTATO 50/300°C KT 170 CLA	THERMOSTAT 50/300°C	THERMOSTAT 50/300°C	THERMOSTAT 50/300°C	TERMOSTATO 50/300°C
32	R65090090	1	TIMER ELETTRM.120' C/POS.MAN.MS65 6935A	TIMER	MINUTERIE	ZEITSCHALTUHR	TEMPORIZADOR
32	R65090110	1	TIMER ELETTRM. 120' C/POS. M. 14000F3120MEO DALLA SETTIMANA 23/2013	TIMER FROM WEEK 23/2103	MINUTERIE DU SEMAINE 23/2013	ZEITSCHALTUHR VOM WOCHEN 23/2013	TEMPORIZADOR DEL SEMANA 23/2013
33	R75400410	2	VENTOLA D.180X77/12 50HZ P.D.	FAN	TURBINE	LUEFTERRAD	PALA VENTILADOR
34	R17103010	1	PORTA COMPLETA REPO84/104 LX	DOOR ASSEMBLY	PORTE COMPLETE	TUER KOMPLETT	PUERTA COMPLETA
	R17105450	1	PORTA COMPLETA SERIGRAFATA REPO84/104 AT	DOOR ASSEMBLY	PORTE COMPLETE	TUER KOMPLETT	PUERTA COMPLETA
35	R58005500	1	FLANGIA GUARNIZIONE MOTORE	MOTOR GASKET BRASS FLANGE	BRIDE JOINT MOTEUR	FLANSCH F. MOTORDICHTUNG	BRIDA JUNTA MOTOR
36	R65110500	2	REGOL. PORT. MARR. ATCH. 10L/h	10 LT/H WATER FLOW REDUCER	REGULATUER DE DEBIT 10 LT.	DURCHFLUSSMONDERER 10L/STD.	REGULADOR DE CAUDAL 10 LT.
37	R70010140	1	GUARNIZIONE SILICONE ROSSO 76x40,3x3	RED GASKET 76x40,3x3	ROUGE JOINT 76x40,3x3	ROTEN DICHTUNG 76x40,3x3	JUNTA ROJA 76x40,3x3
38	R65190080	1	CONDENSATORE 5 µF	CAPACITOR	CONDENSATEUR	KONDENSATOR	CONDENSADOR

